

R-200/11-R Ratchet Assembly

NOTE: Order parts by Catalog Number only.
DO NOT order by Reference Number.

Ref. No.	Catalog No.	Description
—	37777	Ratchet & Handle Assembly
1	38585	Handle
2	39177	Ratchet Assembly
3	39197	Knob
4	39182	Ratchet Housing
5	39172	Spring - Housing
6	39187	Ratchet Ring
7	38830	Spring - Ratchet Ring
8	39192	Pawl
9	39202	Pawl Spring

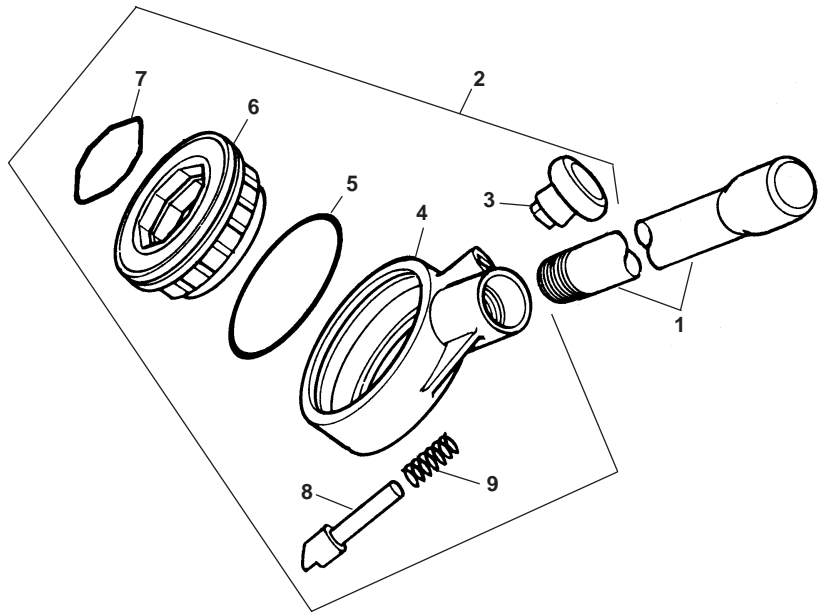

Die Head Assembly

Ref. No.	Description	11-R Catalog No.
1	Die Head w/Cover Plate & Screws	1/8" 38785
		1/4" 38790
		3/8" 38795
		1/2" 38800
		3/4" 38805
		1" NPT/NPSM 38810
		1" BSPT/BSPP 74995
		1 1/4" NPT/NPSM 38815
		1 1/4" BSPT/BSPP 41467
		1 1/2" 14603
		2 14608
		16mm ISO 41477
		20mm ISO 41482
		25mm ISO 41487
		32mm ISO 41482
40mm ISO 41497		
2	Cover Plate Screw (4)	1/8"-1/4" 38720
		3/8"-1 1/4" 38750
		1 1/2"-2" 38940
		16mm - 40mm 38750
3	Cover Plate	1/8" 38715
		1/4" 38735
		3/8" 38745
		1/2" 38760
		3/4" 38770
		1" 38780
		1 1/4" 38880
		1 1/2" 38935
		2 38950

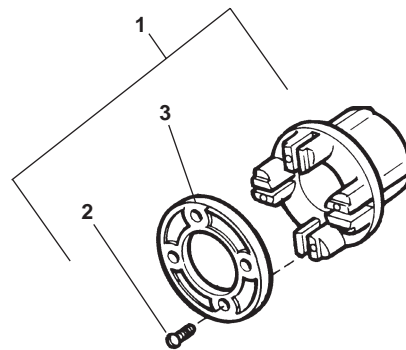

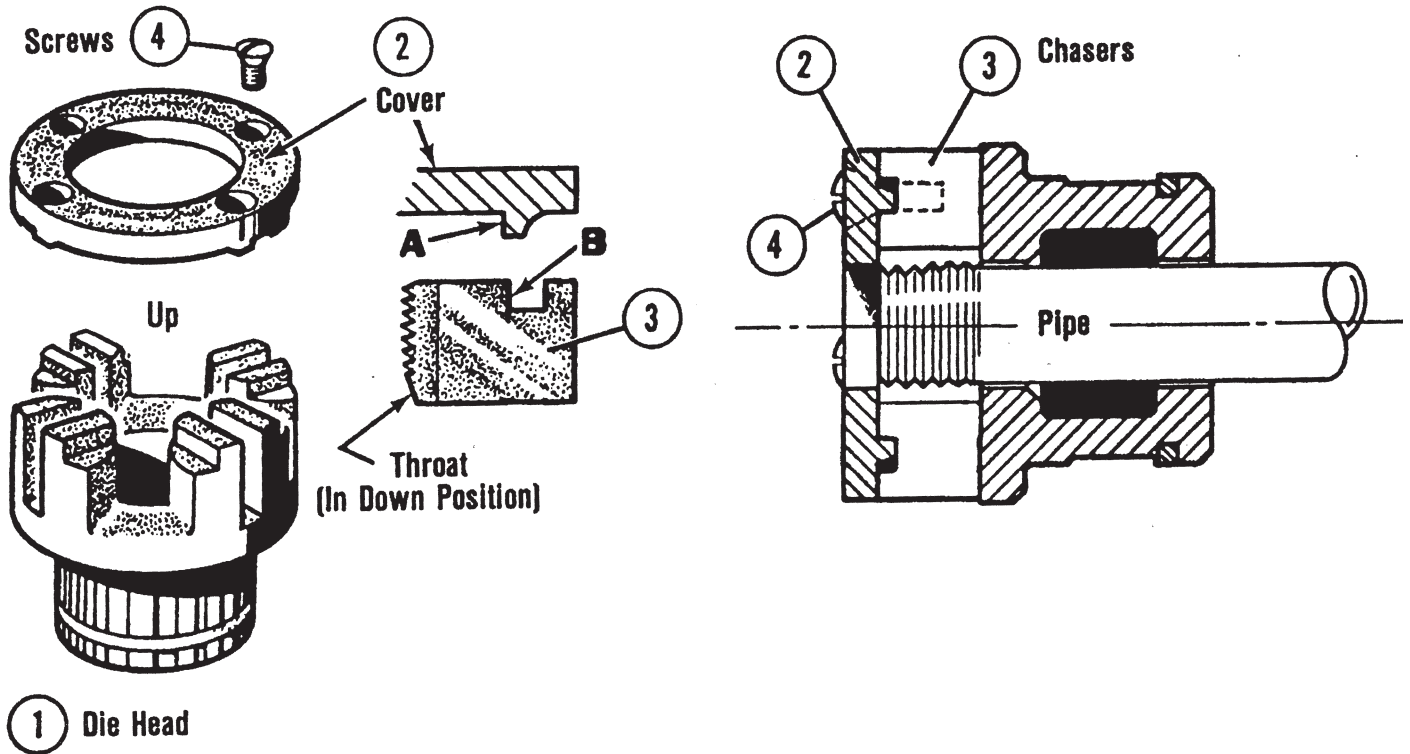

To properly insert new chasers in RIDGID Drop Head Threaders, read the following instructions carefully.

1. Place the Die Head in the position shown at left above.
2. Remove Screws (4), Cover (2), and old Chasers.
3. Insert new Chasers, throats down as shown, into Die Head slots. Numbers on Chasers must agree with those next to Die Head slots.

4. Replace Cover (2), and Screws (4). Tighten the Screws lightly.
5. Slide Die Head on already threaded nipple or pipe, until Chasers begin to thread. This forces Chasers outward against Lugs on Cover Plate. Tighten the 4 Screws securely. The Chasers are set for accurate threading by bringing **B** of Chasers against **A** of the Cover. This is the **Key** to inserting the Chasers properly.